

X-GRIP MINI M

Order number: 0050.2520

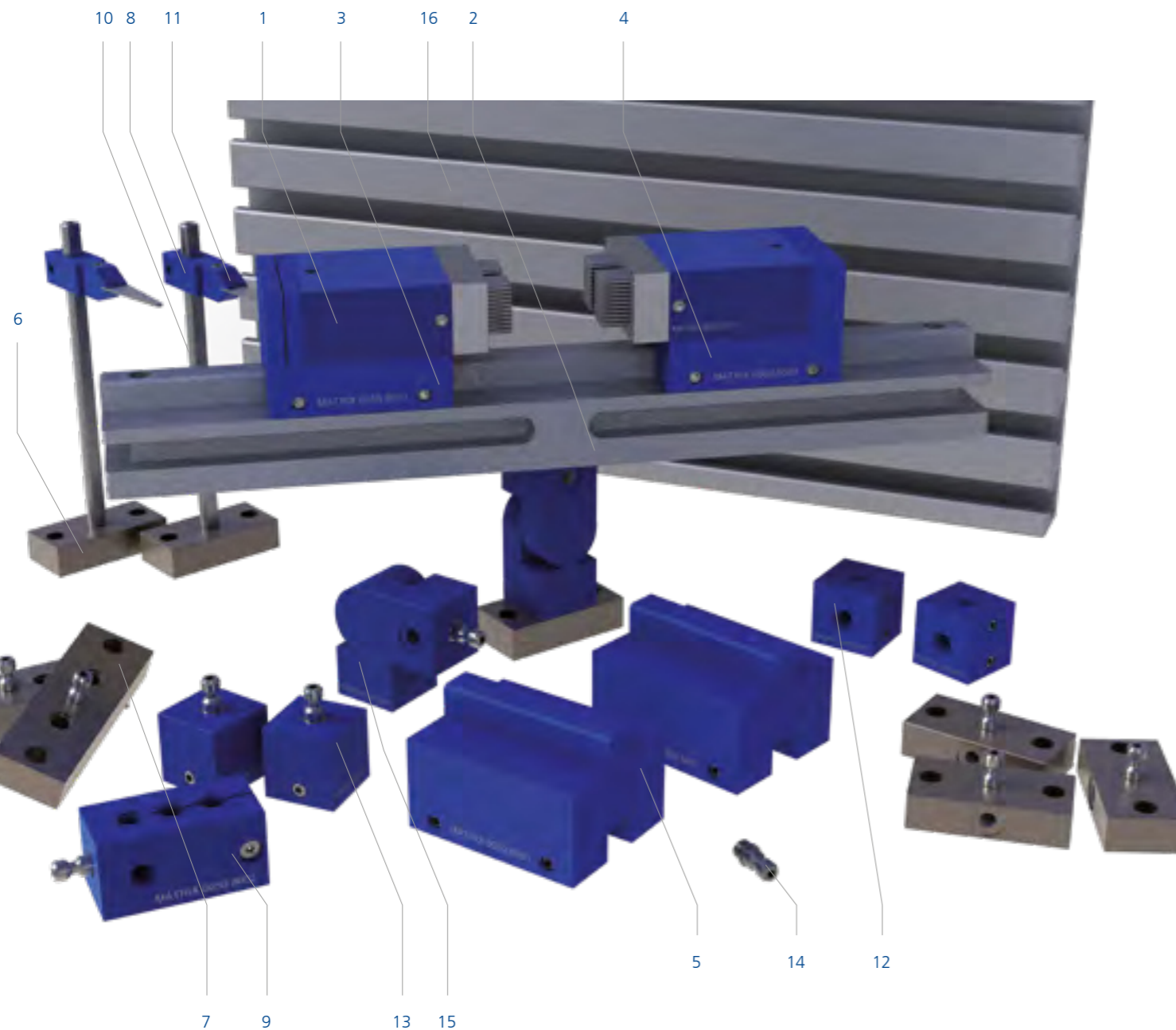

X-GRIP MINI M

The X-GRIP MINI M is a form-closure and fast holding system with two pin-jaws for filigree and lightweight parts with unsurpassed resolution (1 mm pin diameter).



17

The modular system consists of the following individual components:



Fig.	Article no.	Quantity	Description	Dimension	Pin field	Number of pins	Pin diameter	Pin stroke
1	0050.2527	2	X-GRIP MINI Modul double	20 x 40 x 50 mm	14 x 11 mm (x2)	252	1 mm	7,5 mm
Further information about the module:				Weight: 132g, Clamping screw: Hexagon SW2, Material pins: Stainless steel, Material housing: Aluminium anodized, Adaption: Connection pin Ø 5, Instalation location: any, Air connections for cleaning, Data sheet on request				
2	0050.8010	1	Guide rail	250 mm	-	-	-	-
3	0050.8070	1	Carriage, adjustable	-	-	-	-	-
4	0050.8080	1	Carriage, fixed	-	-	-	-	-
5	0050.8060	2	Height adjustment	25 mm	-	-	-	-
6	0050.8009	6	Base plate single	-	-	-	-	-
7	0050.8008	2	Base plate double	-	-	-	-	-
8	0050.8003	2	Holder single	-	-	-	-	-
9	0050.8002	1	Holder double	-	-	-	-	-
10	0050.8052	2	Holding rod	100 mm with scale	-	-	-	-
11	0050.8050	2	Pressure pad	-	-	-	-	-
12	0050.8007	2	Double-joint	90°	-	-	-	-
13	0050.8001	2	Adapter	20 mm	-	-	-	-
14	0050.8013	15	Connection pin with hexagon	M5	-	-	-	-
15	0050.8040	1	Knuckle joint, infinitely variable	-	-	-	-	-
16	0900.0200	1	T-slot profile plate	250 x 200 x 20 mm Slot width: 8 mm	-	-	-	-
17	0900.1000	1	Micro-screwdriver	-	-	-	-	-
-	0900.2503	1 Set = 16 Pcs.	Set of fastening parts for X-GRIP MINI	-	-	-	-	-
-	0900.9005	1	MATRIX case for MINI CLAMP	-	-	-	-	-

