

X-GRIP MINI S

ORDER NUMBER: 0050.2515

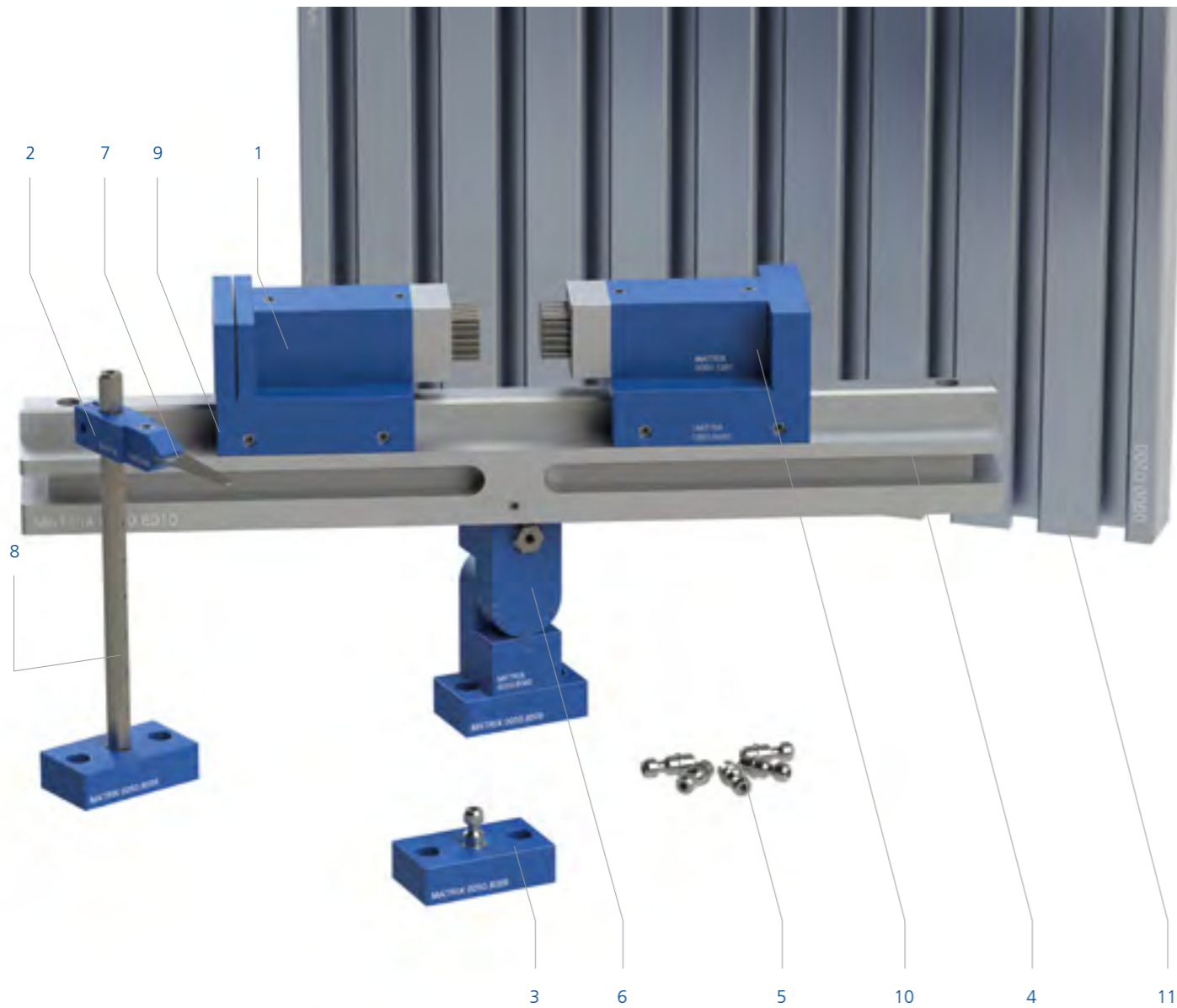

X-GRIP MINI S

The X-GRIP MINI S generates the form-closure and lightning-fast clamping and support for filigree and lightweight parts in unsurpassed resolution (1 mm pin diameter). Toolless operation is also possible.

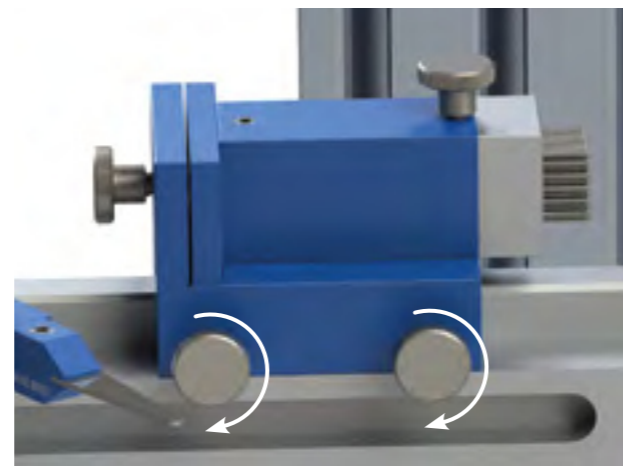

The modular system consists of the following individual components:



Fig.	Article no.	Quantity	Description	Dimension	Pin field	Number of pins	Pin diameter	Pin stroke
1	0050.1267	2	X-Grip Mini single	20 x 20 x 50 mm	14x11 mm(1x)	126	1 mm	7,5 mm
Further information about the module:				Weight: 67g, Clamping screw: Hexagon SW2, Material pins: Stainless steel, Material housing: Aluminium anodized, Adaption: Connection pin Ø 5, Installation location: any, Air connections for cleaning, Data sheet on request				
2	0050.8003	1	X-Grip Mini bracket single	-	-	-	-	-
3	0050.8009	3	X-Grip Mini base plate single	-	-	-	-	-
4	0050.8010	1	X-Grip Mini straight guide	250 mm	-	-	-	-
5	0050.8013	8	X-Grip Mini connection pin with hexagon socket	13,5 mm, M5	-	-	-	-
6	0050.8040	1	X-Grip Mini Single joint, stepless	-	-	-	-	-
7	0050.8050	1	X-Grip Mini retainer	-	-	-	-	-
8	0050.8052	1	X-Grip Mini retaining arm	100 mm with scale	-	-	-	-
9	0050.8070	1	X-Grip Mini movable slide	-	-	-	-	-
10	0050.8080	1	X-Grip Mini fixed slide	-	-	-	-	-
11	0900.0200	1	T-slotted profile plate	250 x 200 x 20 mm Slot width: 8 mm	-	-	-	-
-	0900.1000	1	X-Grip Mini micro-screwdriver	-	-	-	-	-
-	0900.2502	1 Set = 8 pieces	X-Grip Mini mounting kit for X-Grip Mini	-	-	-	-	-
-	0900.9000	1	MATRIX Case incl. product-specific deposit, cover- and groundpad	-	-	-	-	-

