

X-CLAMP 40 MINIATURE MACHINE VISE BASE KIT SMALL

ORDER NUMBER: 0020.3859

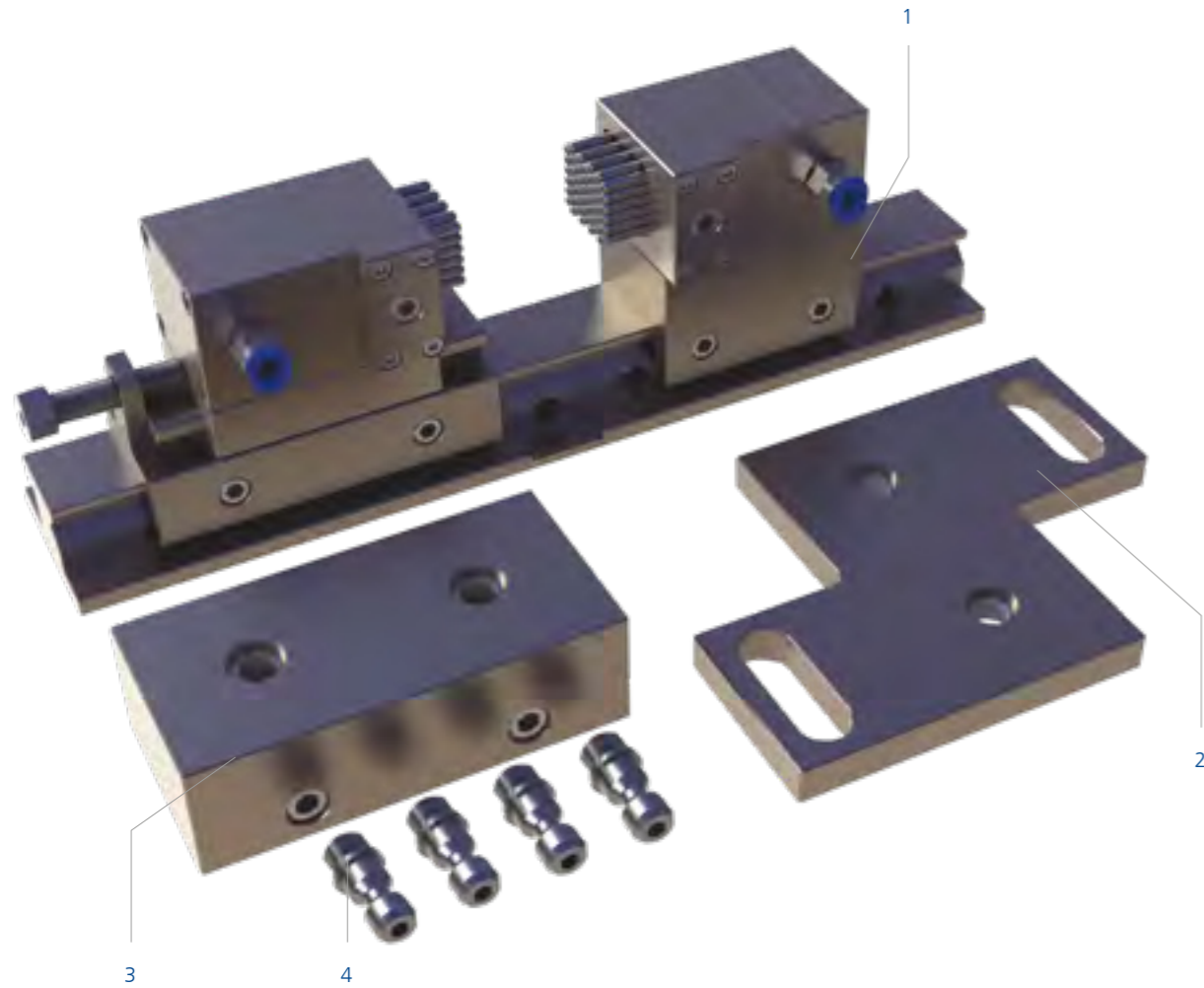

X-CLAMP 40 BASE KIT SMALL

The X-CLAMP 40 miniature machine vise is unbeatable as mold clamping system for small workpieces with complicated shapes.

The modular system consists of the following individual components:

Fig.	Article no.	Quantity	Description	Dimension	Pin field	Number of pins	Pin diameter	Pin stroke
1	0020.3858	1	X-CLAMP 40 Miniature machine vise	38 x 255 x 75 mm	21 x 24 mm	58 Pieces (2x)	3 mm	12 mm
Further information about the module:				Weight: 3 kg, Material housing/pins: Stainless steel, Installation location: any, Cleaning: Air and coolant connections, Data sheet and CAD data on request				
2	0020.0120	1	S-Base plate for X-CLAMP 100	130 x 100 x 10 mm	-	-	-	-
3	0020.3116	1	Adapter for X-CLAMP 100	50 x 100 x 30 mm	-	-	-	-
4	0020.0027	4	Connection pin for X-CLAMP	M10 x 27 mm	-	-	-	-
-	-	1	Torque wrench	MICRO 6-30 Nm	-	-	-	-
-	0900.9000	1	MATRIX case	-	-	-	-	-

X-CLAMP 40 - OPTIONAL

ADD-ONS (TO BE ORDERED SEPERATELY)

Fig.	Article no.	Quantity	Description	Dimension
5	0020.3800	1	Adaptive guide rail for X-CLAMP 40	100 x 50 mm

