

Datenblatt / Datasheet FLEX-Clamp Mini double

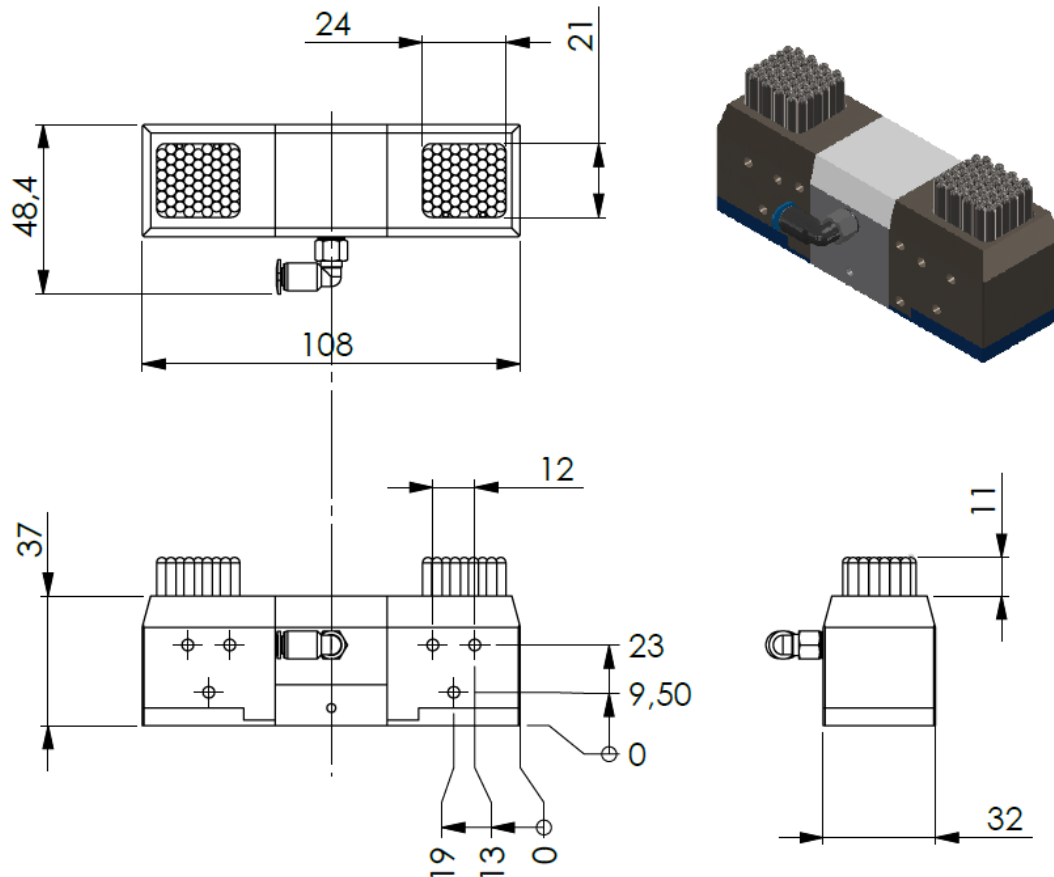

| | |
|---|---------------------------------------|
| Bezeichnung / Description | FLEX-Clamp Mini double |
| Bestellnummer / Order-No. | 0042.1160 |
| Außenabmaße / Dimension B x L x H [mm] | 32 x 108 x 37 |
| Spannfläche / Dim. Pin-field BS x LS [mm] | 2 x 21 x 24 |
| Anzahl Stößel / Number of pins | 116 |
| Durchmesser Stößel / Pin Ø D [mm] | 3 |
| Hub / Pin stroke HB [mm] | 11 |
| Gewicht / Weight [kg] | 410 |
| Spannmechanismus / Clamping mechanism | Pneumatisch / pneumatic |
| Luftverbrauch / Air consumption | 1000 mm ³ / cycle |
| Max. Haltekraft Pinfeld axial passiv / Max. load axial passive | 80N |
| Max. Haltekraft Pinfeld axial aktiv [6bar] / Max. load axial active [6bar] | 180 N |
| Pneumatischer Anschluss / Pneumatic connector (for cleaning) | M3 / QS-4 |
| Betriebsdruck / Pressure | 6 bar gefilterte Druckluft / filtered |
| Einbaulage / Mounting position | Beliebig / any |
| Zubehör / Accessories | - |
| CAD-Daten / CAD-Data | STEP |

MATRIX Automations GmbH
Felix-Wankel-Str. 6
73760 Ostfildern
GERMANY

Phone: +49 (0) 711 / 22 93 28-0
Fax: +49 (0) 711 / 22 93 28-22
eMail: info@matrix-automations.com